

# MTCS 2300 - Pressure

## Thermal Conductivity Sensor for miniature Pirani gauge

### Applications

Miniature Pirani devices and sensors have applications including:

- Leak detection
- Propulsion
- Semiconductor manufacturing (e.g., sputtering chambers)
- Freeze dryers
- Vacuum meat packing machines
- Vacuum coating
- Load locks

In general, pressure measurement following Pirani principle in rough environments with power and size constraints, such as in analytical portable instruments or small mechanical pumping systems

### Silicon Pirani gauge MTCS characteristics

The packaged sensor is available with different possible packaging options:

- Only the sensing die, realizing a miniature hot wire in air
- The sensing die with a silicon lid, creating a gap between the hot and cold part of 10  $\mu\text{m}$  or 20  $\mu\text{m}$ . These small gaps enhance the sensitivity of the Pirani principle at pressures between 100-1000 mbar

### General description

The **MTCS2300** pressure gauge, using thermal conductance measurement according to Pirani principle, is a dedicated MEMS device mounted in a small TO8 or TO39 package. The sensor incorporates one large micro-machined low stress silicon nitride membrane with two thin film resistors for heating and two reference resistors for compensation on silicon bulk using Ni-Pt resistors MEMS technologies in a miniature package. This MEMS structure, combined with simple CMOS standard integrated circuits for current source and temperature analysis, is a suitable choice for size-critical vacuum OEM sensing solution requiring ultra-low power consumption with an excellent signal-to-noise ratio and resistance to corrosive gas.

### Features

- Extended measuring range from  $10^{-4}$  to 1000 mbar
- MEMS Micro machined silicon sensor with perfect matching of the sensor geometry and sensor resistors
- Ultra small sensor gas volume such as  $< 0.1 \text{ cm}^3$
- Pirani microwire-to-wall distance adjusted by silicon micromachining, down to 10  $\mu\text{m}$  or 20  $\mu\text{m}$  with excellent sensor reproducibility
- Ultra-low power consumption in operation ( $< 6 \text{ mW}$ ) due to the use of MEMS based silicon sensor with large integrated resistors such as 250 Ohms and small heated mass
- Ultra-fast response time  $< 50 \text{ ms}$
- Easy temperature compensation due to similar heating and reference resistors, realized in micro structured platinum-nickel thin film process
- Insensitive to mounting position
- High shock survivability ( $>1000 \text{ G}$ ) due to small size
- Resistance to corrosive gas as Hydrogen, using gold contact

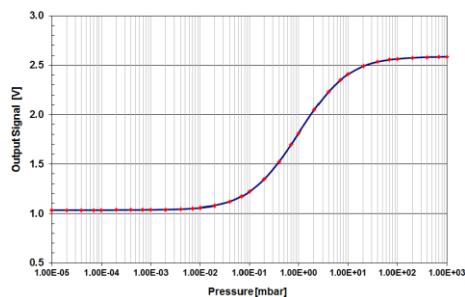

Output Signal versus Pressure in the range  $[10^{-5}; 10^3]$  mbar - Typical curve -

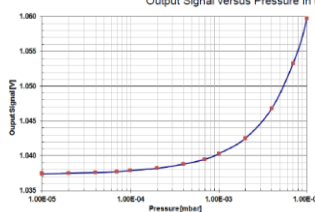

Response detail in the range  $[10^{-5}; 10^{-2}]$  mbar

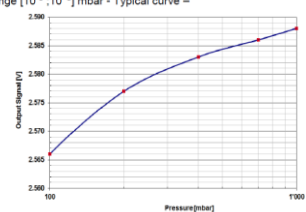

Response detail in the range  $[100; 1'000]$  mbar

## MTCS2301/MTCS2302 sensor electrical characteristics

	Symbol	Min	Typical	Max	Units
Measuring resistor ( $R_{m1}$ and $R_{m2}$ )	$R_{m1}$ and $R_{m2}$	110	120	135	$\Omega$
Reference resistor	$R_{t1}$ and $R_{t2}$	240	270	300	$\Omega$
Absolute ( $R_{m1}-R_{m2}$ )			< 1.5		$\Omega$
Absolute ( $R_{t1}-R_{t2}$ )			< 5.5		$\Omega$
$R_{tx}/(R_{m1} + R_{m2})$			1.0 to 1.2		
Thermal coefficient	$\alpha$	0.0045	0.0050	0.0055	/°K
Defined gas gap between hot and cold part		10	20	200	$\mu\text{m}$

## Sensor package information

MTCS sensor in TO8 metallic header, with 8 isolated leads (TO8 size)

### Package size:

External diameter: 13.00 mm

Internal diameter: 10.85 mm

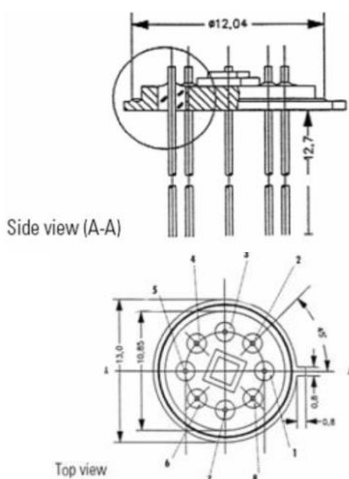

### Bonding:

Gold or aluminum wires, 30  $\mu\text{m}$  diameter

### Pins list:

1 - 8:  $R_{m1}$

2 - 7:  $R_{m2}$

3 - 4:  $R_t$

5 - 6:  $R_T$  (temp. resistor)

○ : Pins connected to case

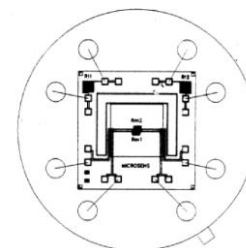

### Mounting principle and parts exposed to vacuum:

- Dies glued with epoxy glue (120°C, 80 minute curing, ultra-low degassing)
- Material exposed to vacuum: gold or aluminum, bulk silicon, silicon dioxide, silicon nitride, fused quartz

### Sensor package remarks:

MTCS sensor can also be directly PCB or COB mounted.

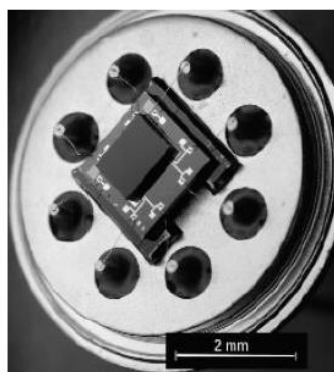
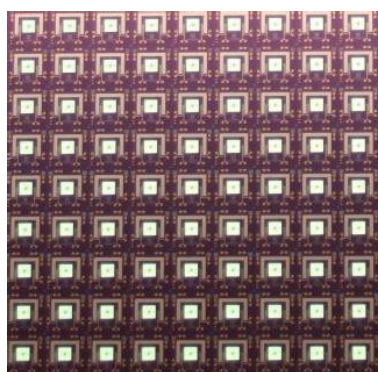

## Ordering Information

MTCS230X	X = 1 : MTCS2301 = Al contact	X = 2 : MTCS2302 = Au contact
Part number	Description	
MTCS230X-0	Only one sensing die, no silicon cap or silicon lid, in TO8	
MTCS230X-10	Sensing die with a cap lid of 10 $\mu\text{m}$ air gap, in TO8	
MTCS230X-20	Sensing die with a cap lid of 20 $\mu\text{m}$ air gap, in TO8	

## MTCS2303/MTCS2304 sensor electrical characteristics

	Symbol	Min	Typical	Max	Units
Measuring resistor ( $R_{m1}$ and $R_{m2}$ )	$R_{m1}$ and $R_{m2}$	110	120	135	$\Omega$
Reference resistor	$R_t$	240	270	300	$\Omega$
Absolute ( $R_{m1}-R_{m2}$ )			< 1.5		$\Omega$
Absolute ( $R_{t1}-R_{t2}$ )			< 5.5		$\Omega$
$R_{tx}/(R_{m1} + R_{m2})$			1.0 to 1.2		
Thermal coefficient	$\alpha$	0.0045	0.0050	0.0055	/°K
Defined gas gap between hot and cold part		10	20	200	$\mu\text{m}$

## Sensor package information

MTCS sensor in TO5-6 metallic header, with 6 isolated leads and 2 ground leads (TO39 size)

### Package size:

External diameter Ext D: 9.00 mm  
 Internal diameter Int D: 8.65 mm  
 Total Thickness Ltot: 1.55 mm  
 Border thickness l: 0.55 mm

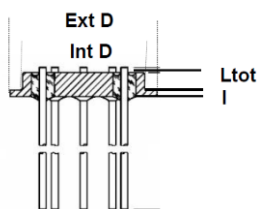

### Mounting principle and parts exposed to vacuum:

- Dies glued with epoxy glue (120°C, 80 minute curing, ultra-low degassing)
- Material exposed to vacuum: gold or aluminum, bulk silicon, silicon dioxide, silicon nitride, fused quartz

### Sensor package remarks:

MTCS sensor can also be directly PCB or COB mounted.

### Bonding:

Gold or aluminum wires, 30  $\mu\text{m}$  diameter

### Pins list:

- 1 - 6 :  $R_{m1}$
  - 6 - 2 :  $R_{m2}$
  - 1 - 2 :  $R_m = R_{m1} + R_{m2}$
  - 2 - 3 :  $R_t$
  - 4 - 5 :  $R_T$  (temp. resistor)
- : Pins connected to case

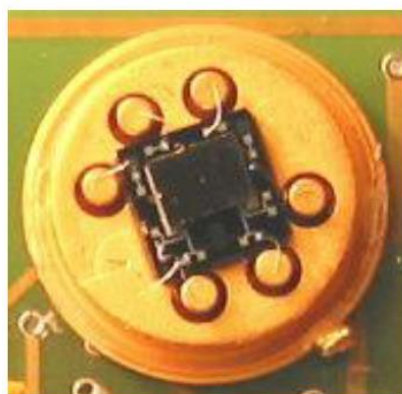
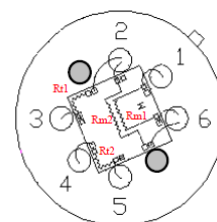
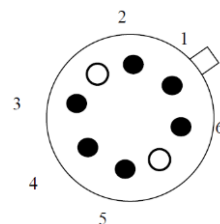

Pressure signal of miniature Pirani sensor MTCS2303 using a constant temperature interface

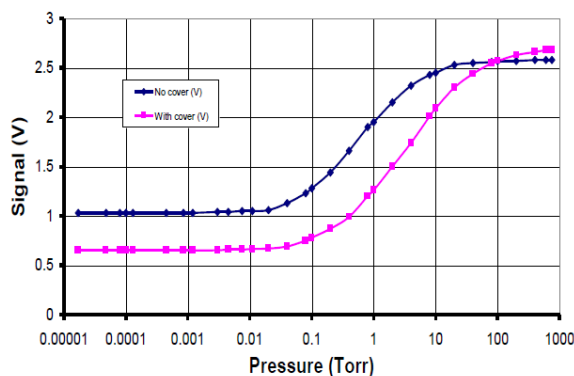

## Ordering Information

MTCS230X	X = 3 : MTCS2303 = Al contact	X = 4 : MTCS2304 = Au contact
Part number	Description	
MTCS230X-0	Only one sensing die, no silicon cap or silicon lid, in TO5-6	
MTCS230X-10	Sensing die with a cap lid of 10 $\mu\text{m}$ air gap, in TO5-6	
MTCS230X-20	Sensing die with a cap lid of 20 $\mu\text{m}$ air gap, in TO5-6	

## MTCS2305/MTCS2306 sensor electrical characteristics

	Symbol	Min	Typical	Max	Units
Measuring resistor Rm	Rm	220	240	270	$\Omega$
Reference resistor Rt	Rt	480	540	600	$\Omega$
Rt/Rm			2.1 to 2.4		$\Omega$
Thermal coefficient	$\alpha$	0.0045	0.0050	0.0055	/°K
Defined gas gap between hot and cold part		10	20	200	$\mu\text{m}$

## Sensor package information

MTCS sensor in TO5-4 metallic header, with 3 isolated leads and 1 ground leads (TO39 type)

### Package size:

(deliver with or without metallic cap)  
 External diameter Ext D: 9.10 mm  
 Internal diameter Int D: 7.60 mm  
 Total Thickness Ltot: 1.76 mm  
 Border thickness l: 0.50 mm

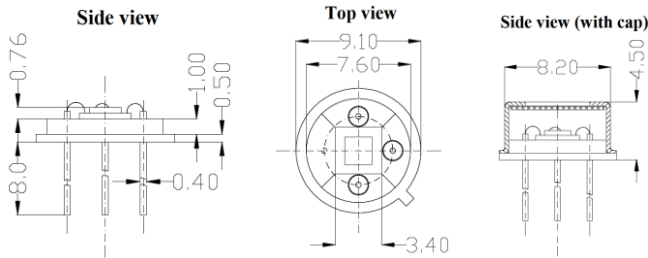
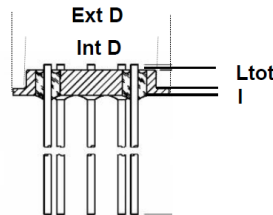

### Bonding:

Aluminum wires, 30  $\mu\text{m}$  diameter

### Pins list:

- 1 : COM
- 2 : Rt
- 3 : Shield
- 4 : Rm

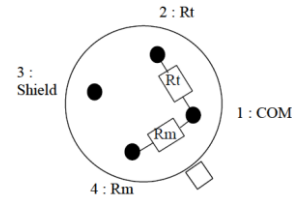

### Mounting principle and parts exposed to vacuum:

- Dies glued with epoxy glue (120°C, 80 minute curing, ultra-low degassing)
- Material exposed to vacuum: gold or aluminum, bulk silicon, silicon dioxide, silicon nitride, fused quartz

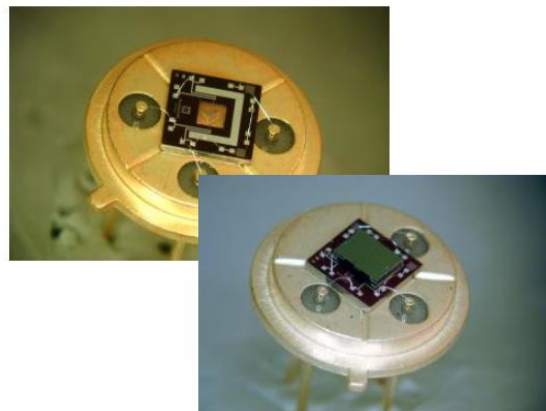

## Ordering Information

Part number	Description
MTCS230X	X = 5 : MTCS2305 = Al contact X = 6 : MTCS2306 = Au contact
MTCS230X-0	Only one sensing die, no silicon cap or silicon lid, in TO5-4
MTCS230X-10	Sensing die with a cap lid of 10 $\mu\text{m}$ air gap, in TO5-4
MTCS230X-20	Sensing die with a cap lid of 20 $\mu\text{m}$ air gap, in TO5-4

# NEROXIS

NEROXIS SA | Rue Jaquet-Droz 1 | CH-2002 Neuchâtel | SWITZERLAND  
 Email: kaptadmin.vws@veolia.com | Tel: +41 32 720 57 57  
[www.neroxis.ch](http://www.neroxis.ch)